

Xenon Lamps for NEC Digital Cinema Projector

DXL-21SN3

Technical Data

Input Power	W	-	2000	
Voltage	V	-	26	
Current	A	-	75	
Lamp Length	mm	a	387	
LCL	mm	b	171.5	
Cold Arc Gap	mm	c	4	
Cathode	Base Diameter	mm (Φ)	d	27
	Pin Diameter	mm (Φ)	e	20
	Pin Length	mm	f	14
Anode	Base Diameter	mm (Φ)	g	30
	Pin Diameter	mm (Φ)	h	14
	Pin Length	mm	i	13.5
Bulb diameter	mm (Φ)	j	53	
Cable length	mm	k	220	
Crimping terminal	mm	l	22-10	

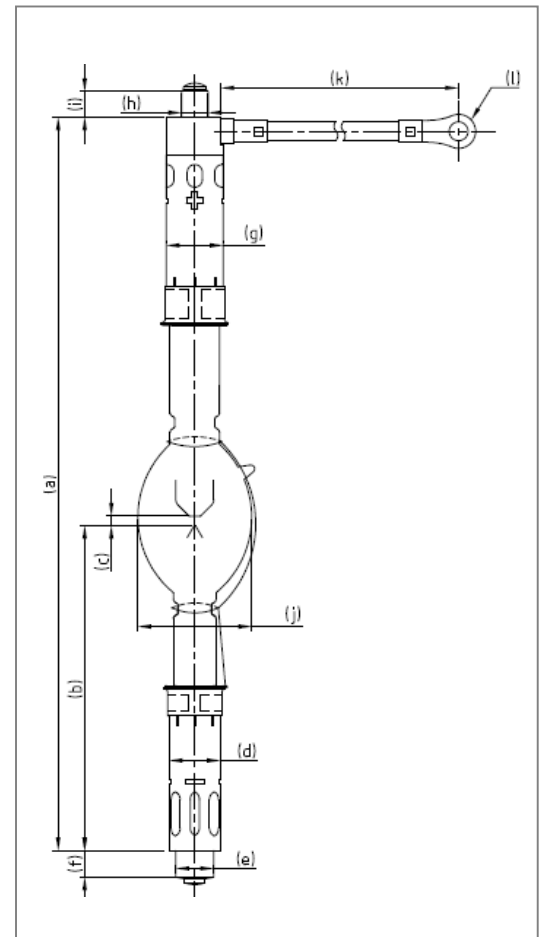

Warranty Hours

DXL-21SN3	2400
-----------	------

Cross Reference

Lamp Type	Projector Model
DXL-21SN3	NC2500S NC3200S NC3240S